

## MRS installation and user's guide

[www.renishaw.com](http://www.renishaw.com)

# MRS installation and user's guide

Documentation part number H-1000-5088-06-D



## MRS installation and user's guide

www.renishaw.com

# General information

© 2001 - 2021 Renishaw plc. All rights reserved.

 ORIGINAL LANGUAGE VERSION

This document may not be copied or reproduced in whole or in part, or transferred to any other media or language by any means, without the prior written permission of Renishaw.

## Disclaimer

WHILE CONSIDERABLE EFFORT WAS MADE TO VERIFY THE ACCURACY OF THIS DOCUMENT AT PUBLICATION, ALL WARRANTIES, CONDITIONS, REPRESENTATIONS AND LIABILITY, HOWSOEVER ARISING, ARE EXCLUDED TO THE EXTENT PERMITTED BY LAW.

RENISHAW RESERVES THE RIGHT TO MAKE CHANGES TO THIS DOCUMENT AND TO THE EQUIPMENT, AND/OR SOFTWARE AND THE SPECIFICATION DESCRIBED HEREIN WITHOUT OBLIGATION TO PROVIDE NOTICE OF SUCH CHANGES.

## Trade marks

RENISHAW<sup>®</sup>, the probe symbol and REVO<sup>®</sup> are registered trade marks of Renishaw plc.

Renishaw product names, designations and the mark 'apply innovation' are trade marks of Renishaw plc or its subsidiaries.

Other brand, product or company names are trade marks of their respective owners.

## WEEE



The use of this symbol on Renishaw products and / or accompanying documentation indicates that the product should not be mixed with general household waste upon disposal. It is the responsibility of the end user to dispose of this product at a designated collection point for waste electrical and electronic equipment (WEEE) to enable reuse or recycling. Correct disposal of this product will help to save valuable resources and prevent potential negative effects on the environment. For more information, please contact your local waste disposal service or Renishaw distributor.

## Warranty

Unless you and Renishaw have agreed and signed a separate written agreement, the equipment and/or software are sold subject to the Renishaw Standard Terms and Conditions supplied with such equipment and/or software, or available on request from your local Renishaw office.

Renishaw warrants its equipment and software for a limited period (as set out in the Standard Terms and Conditions), provided that they are installed and used exactly as defined in associated Renishaw documentation. You should consult these Standard Terms and Conditions to find out the full details of your warranty.

Equipment and/or software purchased by you from a third-party supplier is subject to separate terms and conditions supplied with such equipment and/or software. You should contact your third-party supplier for details.

## MRS installation and user's guide

[www.renishaw.com](http://www.renishaw.com)

### Care of equipment

Renishaw probes and associated systems are precision tools used for obtaining precise measurements and must therefore be treated with care.

### Changes to Renishaw products

Renishaw reserves the right to improve, change or modify its hardware or software without incurring any obligations to make changes to Renishaw equipment previously sold.

### Company registration details

Renishaw plc. Registered in England and Wales. Company no: 1106260. Registered office: New Mills, Wotton-under-Edge, Gloucestershire, GL12 8JR, UK.

### Packaging

To aid end user recycling and disposal the materials used in the different components of the packaging are stated here:

Packaging component	Material	94/62/EC code	94/62/EC number
Outer box	Corrugated fibreboard	PAP	20
Packaging insert	Paper	PAP	22

## MRS installation and user's guide

[www.renishaw.com](http://www.renishaw.com)

# Product compliance

## EU declaration of conformity

Contact Renishaw plc or visit [www.renishaw.com/EUCMM](http://www.renishaw.com/EUCMM) for the full EU declaration.

---

## UK declaration of conformity

Contact Renishaw plc or visit [www.renishaw.com/UKCMM](http://www.renishaw.com/UKCMM) for the full UK declaration.

---

## REACH regulation

Information required by Article 33(1) of Regulation (EC) No. 1907/2006 ("REACH") relating to products containing substances of very high concern (SVHCs) is available at:

[www.renishaw.com/REACH](http://www.renishaw.com/REACH)

---

## China RoHS

Contact Renishaw plc or visit [www.renishaw.com/ChinaRoHSCMM](http://www.renishaw.com/ChinaRoHSCMM) for the full China RoHS tabulation.



## MRS installation and user's guide

www.renishaw.com

# References and associated documents

For instructions on fitting, datuming and operation of the ACR3, FCR25, SCP80, SCR600, RCP rack and port assemblies, please refer to the following documents:

Title	Document number	Relevant topics
<a href="#">Installation and user's guide: ACR3</a>	H-1000-5087	ACR3 autochange rack
<a href="#">Installation and user's guide: SP25M system</a>	H-1000-5104	FCR25 and FCR25 TC
<a href="#">Installation and integration guide: SP80</a>	H-1000-5212	SCP80 stylus change port
<a href="#">User's guide: SP80</a>	H-1000-5213	SCP80 stylus change port
<a href="#">Installation leaflet: SCP600</a>	H-1000-5097	SCP600 stylus change port
<a href="#">User's guide: REVO</a>	H-1000-5129	RCP, RCP TC-2, SFCP, SFA, TDA and REVO

## MRS installation and user's guide

www.renishaw.com

# System description

The MRS is designed to provide a flexible platform for Renishaw probe and stylus changing racks.

The system comprises of an extruded aluminium rail mounted to the CMM table by two leg assemblies. It is available in rail lengths of 400 mm (15.75 in), 600 mm (23.62 in), 900 mm (35.43 in) and 1000 mm (39.37 in) to suit a variety of port and rack changing requirements. Custom rail lengths are also available.

The MRS can be placed at different heights from the CMM table by using multiples of the MRS standard and heavy duty legs, thus allowing clearance for long styli and extension bars.

The interconnecting MRS legs supplied (four per kit) are each 125 mm (4.92 in) long. A maximum recommended leg length of 500 mm (19.69 in) can be achieved by purchasing additional legs. These are available in either 62.5 mm (2.46 in) or 125 mm (4.92 in) lengths. The combined MRS rack and leg assembly is mounted on the CMM table via two MRS feet (see item 7 in illustration below). These extend the overall height by 35 mm allowing a maximum clearance of 535 mm between the CMM table and the underside of the MRS rail.

## Modular rack system compatibility

The MRS is compatible with the following Renishaw port and change rack systems:

- |   |  |
|---|--|
| <ul style="list-style-type: none"> <li>● ACR3 (autochange rack)</li> <li>● FCR25 (flexible change rack)</li> <li>● FRC25 TC (thermally controlled flexible change rack)</li> <li>● SCP80 (stylus change port for SP80)</li> <li>● SCP600 (stylus change port for SP600, SP600M and SP600Q)</li> </ul> | <ul style="list-style-type: none"> <li>● RCP TC-2 (thermally controlled REVO change port)</li> <li>● RCP2 (change port for RSH stylus holders)</li> <li>● SFA and SFCP (for REVO surface finish probe)</li> <li>● TDA (REVO tip datum artefact)</li> </ul> |
|---|--|

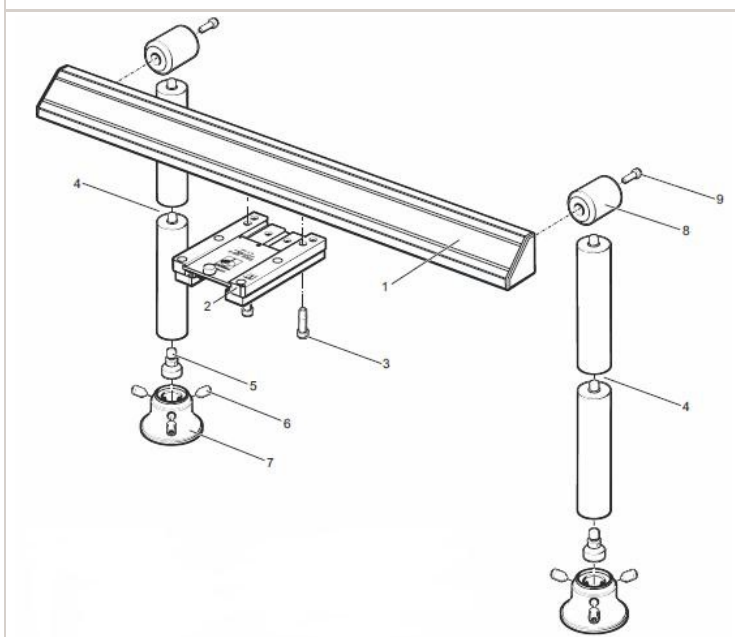

### Key

1. MRS rail
2. Port or rack
3. Fixing screw
4. MRS leg
5. Leg to foot adaptor
6. Grubscrews
7. MRS foot
8. Step-back adaptor
9. M8 screw

# MRS installation and user's guide

www.renishaw.com

## MRS heavy duty legs

Where heavier rack systems or longer styli configurations are used, such as multiple SCP80s or RCP TC-2s, the MRS system can be upgraded by using optional heavy-duty legs that are 60 mm (2.36 in) in diameter and 350 mm (13.78 in) long. These legs are mounted to the CMM table beneath the standard legs and feet.

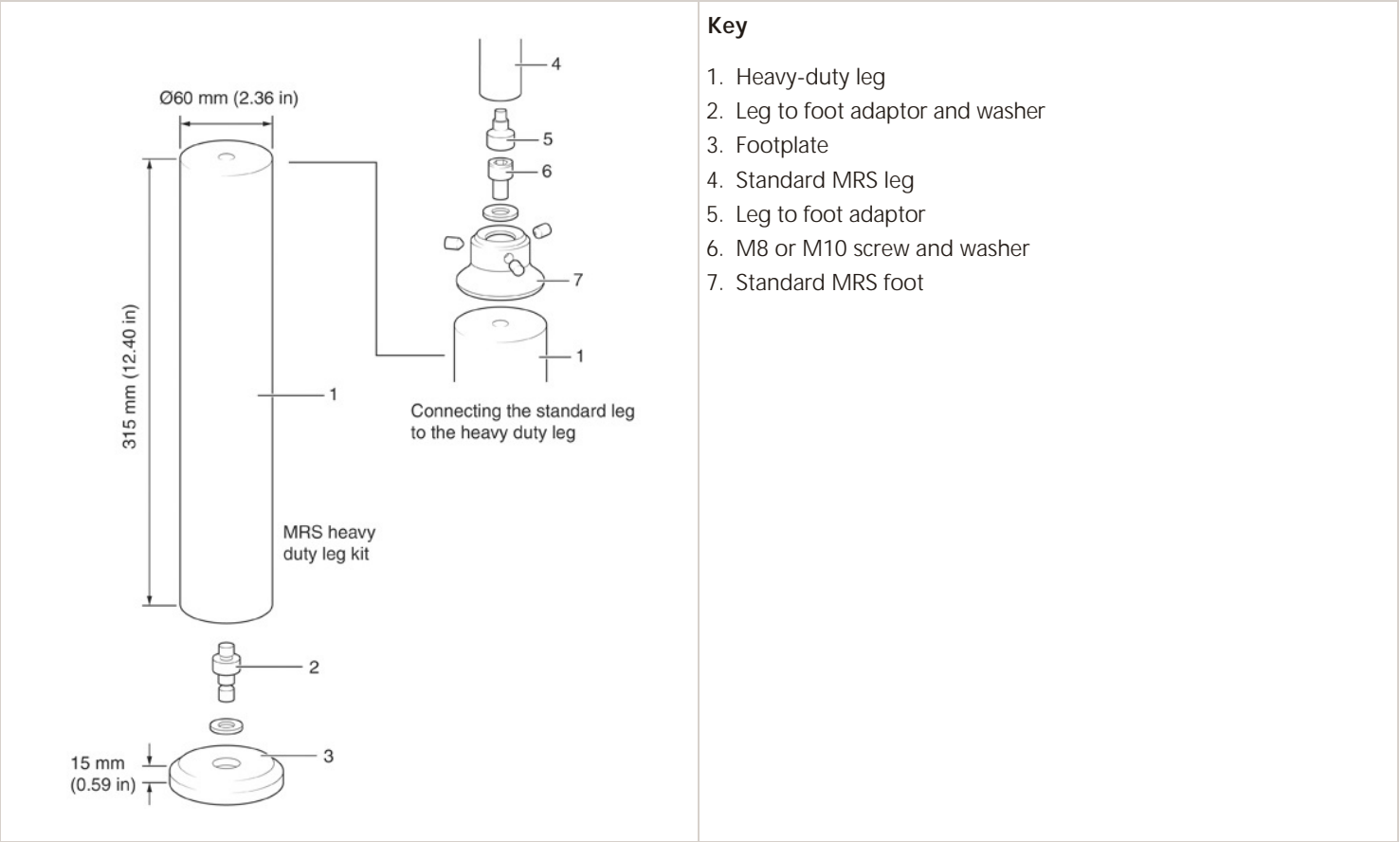

**i** **NOTE:** The MRS heavy-duty leg kit part number is A-4192-0020 and comprises one heavy-duty leg assembly. Two kits are required for each MRS installation.

# MRS installation and user's guide

www.renishaw.com

## MRS adjustable footplates

By using optional MRS adjustable footplates, the MRS rail can be set back on the CMM table to maximise the available working volume of the machine. The MRS adjustable footplates can be used with both standard and heavy-duty leg arrangements. Adjustment is set by the footplate bolt hole spacing in increments of 25 mm, 50 mm, 75 mm, 100 mm (0.98 in, 1.97 in, 2.95 in, 3.94 in).

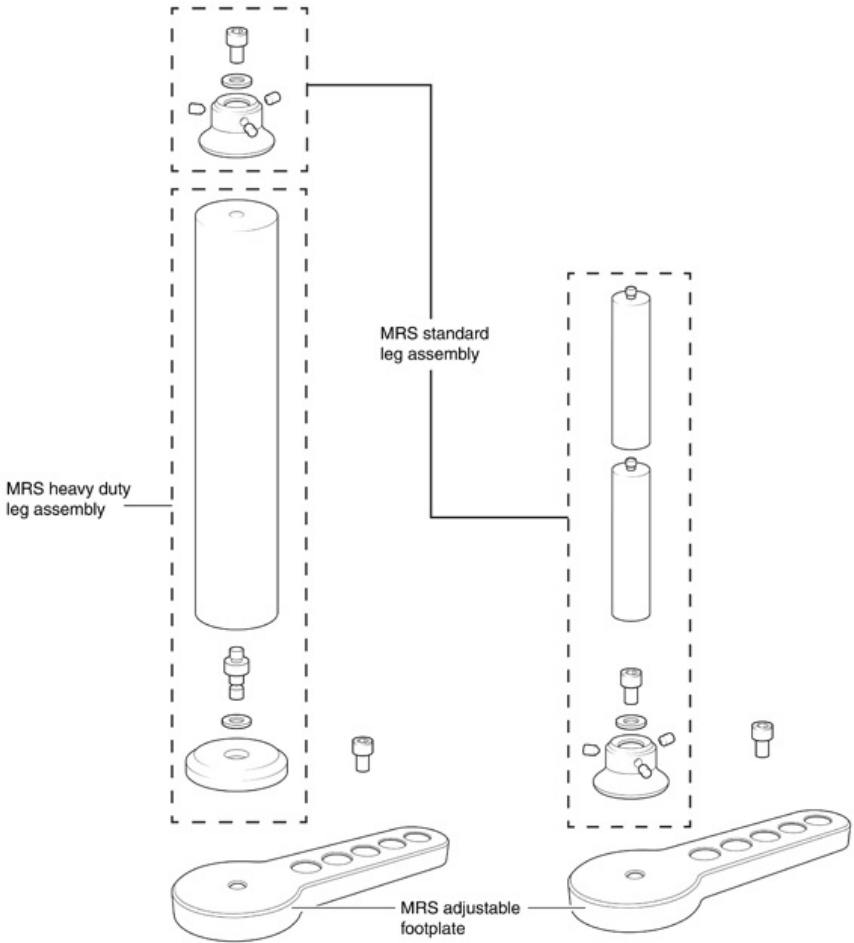

**i** **NOTE:** The MRS adjustable footplate kit part number is A-4192-0702 and comprises two footplates. One kit is required for each MRS installation.



## MRS installation and user's guide

[www.renishaw.com](http://www.renishaw.com)

### Step back adaptor

Step back adaptors can be used to set the MRS rail back on the CMM bed to maximise the available working volume of the machine.

A step back spacer is available to allow the RCP TC-2 to fit in front of the MRS leg.

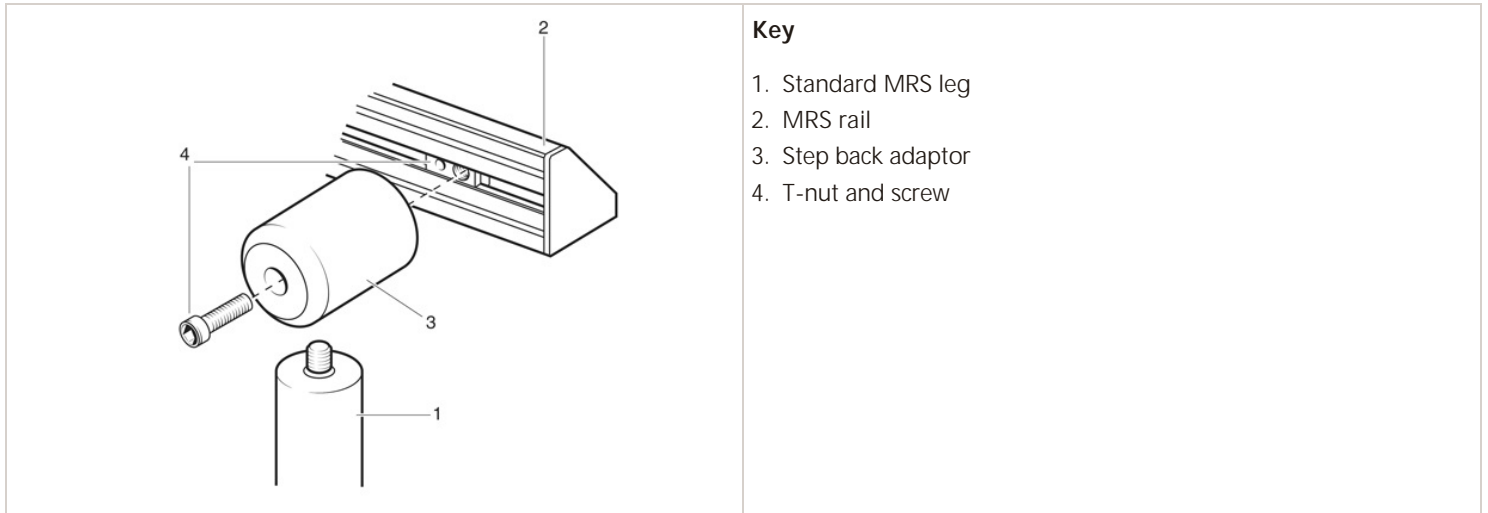

## MRS installation and user's guide

www.renishaw.com

# Fitting the MRS feet

## Fitting the MRS feet to the CMM

The MRS feet should be fitted to the CMM table along either the X or Y axis. The following procedure details the installation.

1. Place the MRS foot (item 3 in illustration below) on the CMM table and position it over the chosen mounting hole. The feet do not require any rotational alignment.
2. Two pairs of screws are supplied with the MRS\*, one pair of M10 and one pair of M8 (item 1) with washers (item 2). The appropriate screw size should be used to secure the MRS foot to the CMM table.
3. Tighten the bolt using the hexagonal key supplied.
4. Fit the second foot at the appropriate distance along the chosen axis following steps 1 to 3 above.

\* If the bolts supplied do not fit the CMM table then suitable alternatives should be found.

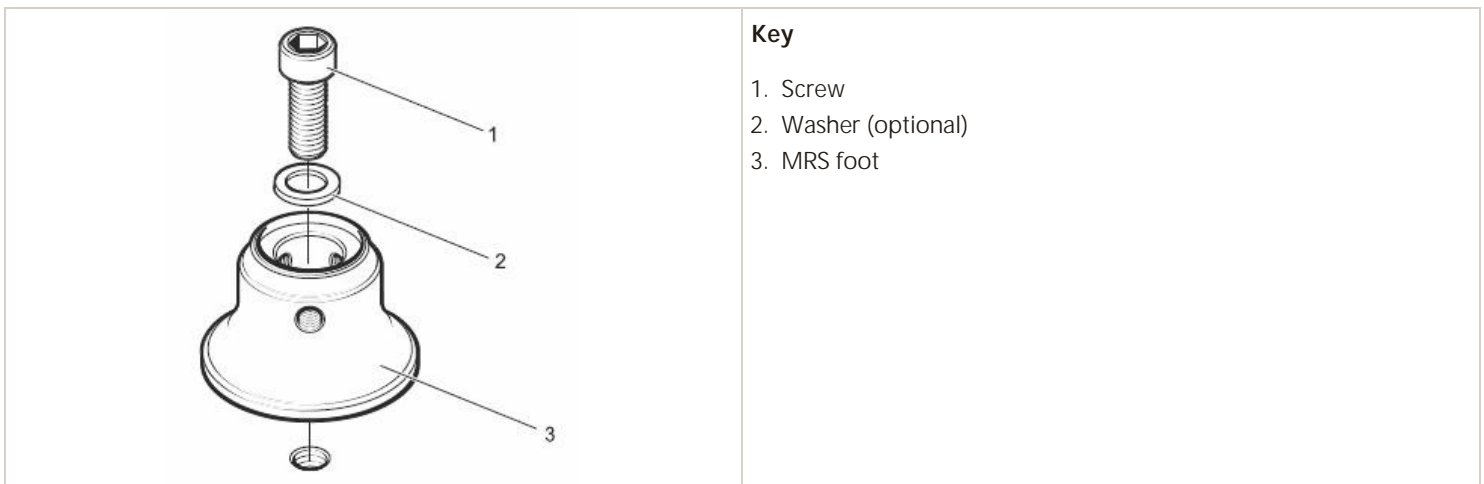

## Aligning the MRS feet to a CMM axis

To ease installation of the rail to the MRS it is recommended that the MRS feet be aligned to a CMM axis. The procedure is as follows:

1. Measure the internal diameter of one of the MRS feet and make this a datum.
2. Measure the internal diameter of the other MRS foot.
3. Calculate the out-of-position angle of the MRS feet using the following formula:

$$\text{arc TAN} \left\{ \frac{\text{X axis position of circle 2}}{\text{Y axis position of circle 2}} \right\} = \text{Angle}$$

(recommended <0.5°)

If the angle exceeds 0.5° then adjustment is necessary. Changing the relative foot position is achieved by releasing the bolt that holds the foot to the CMM table, moving the foot and then re-tightening the bolt. Steps 1 to 3 above should then be repeated.

## MRS installation and user's guide

www.renishaw.com

# Fitting standard legs to the MRS

Two options are available for mounting the legs to the rail of the MRS. The direct fitting option allows legs to be attached onto the underside of the rail. Using the step-back adaptor option allows legs to be fitted to the back of the rail and provides more measuring volume. Recommended procedures for these two options are detailed in this section.



**WARNING:** The MRS rail is shipped without the plastic end-caps fitted. Therefore there is a possibility that sharp edges could be exposed.

## Direct fitting of legs to the MRS rack

The method for directly fitting legs to the MRS rack is as follows:

1. Referring to the illustration below, slide the T-nuts (item 1) into the T-nut slot in the underside of the MRS rail (item 2), one T-nut is required for each leg. Ensure that the longer portion of the T-nut is facing away from the end of the rail. The appropriate number of T-nuts should be placed into the slot for the change port or rack device to be used.
2. Once all the T-nuts have been installed in the correct orientation, the plastic end caps (item 3) can be pressed into the rail.

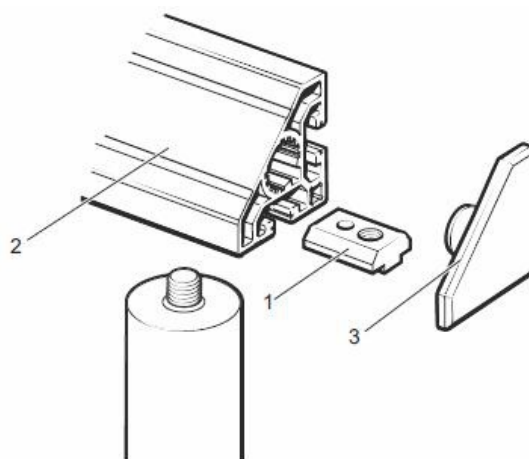

3. Referring to the image below, connect the required number of legs and / or leg extensions (item 1) (up to a maximum of four per leg assembly) and hand-tighten. The MRS leg-to-foot adaptors (item 2) can now be screwed into the bottom of each leg and hand-tightened.
4. Place the MRS legs into the MRS feet (item 3) on the CMM table and adjust the three grub screws (item 4) so that the legs locate in the MRS feet but are still able to rotate.

## MRS installation and user's guide

www.renishaw.com

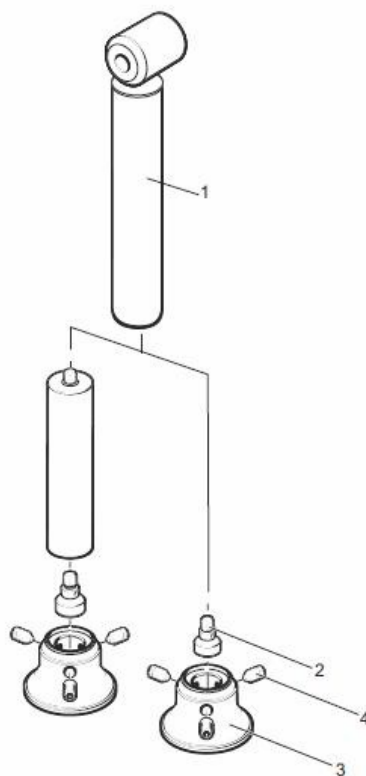

**CAUTION:** The MRS rack is top heavy. Whilst performing steps 5 and 6, the rail of the MRS must be supported.

5. Referring to the image below, screw the MRS legs (item 3) into the T-nuts (item 1) at each end of the MRS rack (item 2) and hand-tighten.
6. When the MRS rack is firmly located on the MRS legs, tighten the three grub screws on each MRS foot using the hexagonal key provided.

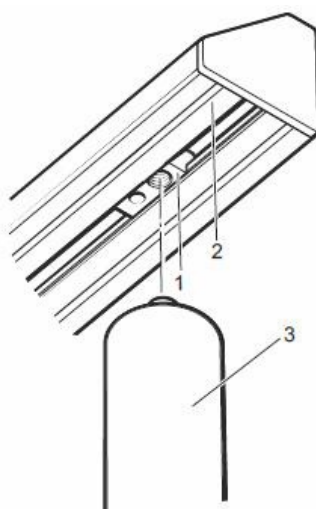

### Fitting MRS legs with step-back adaptors

The following method describes the attachment of MRS legs with step-back adaptors to the MRS rack:

## MRS installation and user's guide

www.renishaw.com

1. Referring to the image below, insert the asymmetrical T-nut (item 3) for the step-back attachment into the rear T-nut slot of the MRS rail (item 2). Ensure that the longer portion of the T-nut is facing away from the end of the rail.
2. The relevant port or rack mounting T-nuts (item 1) should be installed in the T-nut slot in the underside of the rail. The longer portion of the T-nut should face towards the centre of each respective port.
3. Once all the T-nuts have been installed in the correct orientation, the plastic end caps (item 4) can be pressed into the ends of the MRS.

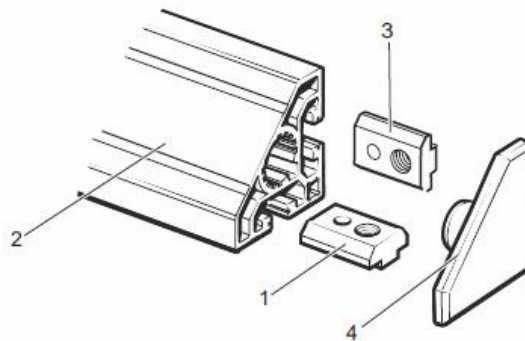

4. Referring to the image in below, insert the M8 screw (item 1) into the step-back adaptor (item 2). Screw the MRS leg (item 3) into the step-back adaptor and hand-tighten. Then screw the required number of leg extensions (up to a maximum of four per leg assembly) into the MRS leg and hand-tighten.

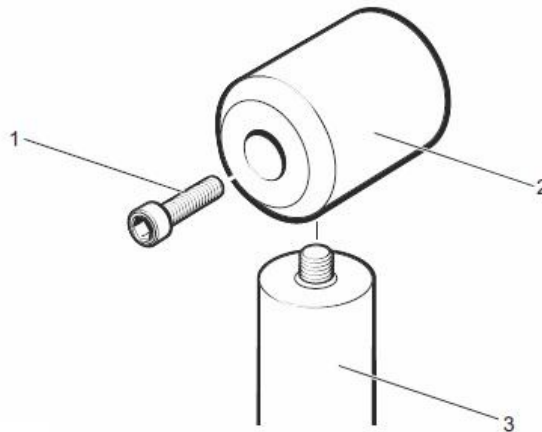

5. Referring to the image below, once the required number of legs or leg extensions have been attached, the MRS leg-to-foot adaptors (item 2) can be screwed into the bottom of each MRS leg assembly (item 1) and hand-tightened.
6. Place the MRS legs into the MRS feet (item 3) on the CMM table. Loosely adjust the three grub screws (item 4) on each MRS foot so that the legs locate in the MRS feet but are free to rotate.

## MRS installation and user's guide

www.renishaw.com

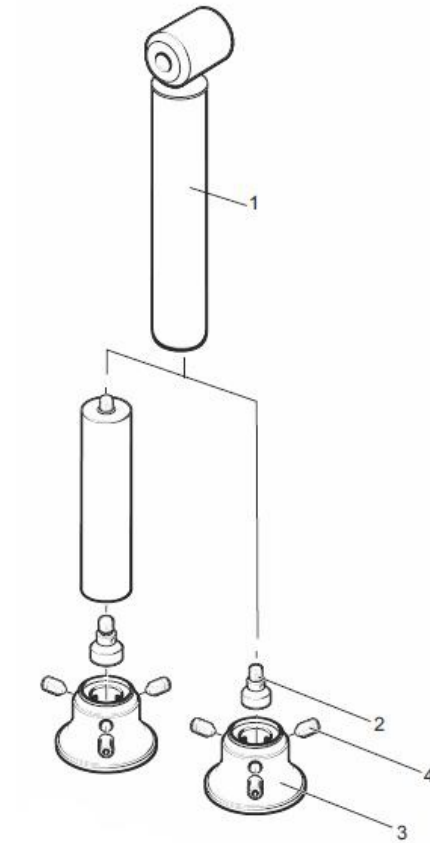

7. If no step back spacer that is required for the RCP and RCP TC-2, position the MRS (item 1) to the step-back adaptor (item 2) and orientate the step-back adaptor so that the M8 screw (item 3) is properly aligned to the MRS T-nut. Screw the step-back adaptor to the MRS using the M8 screw (item 3).

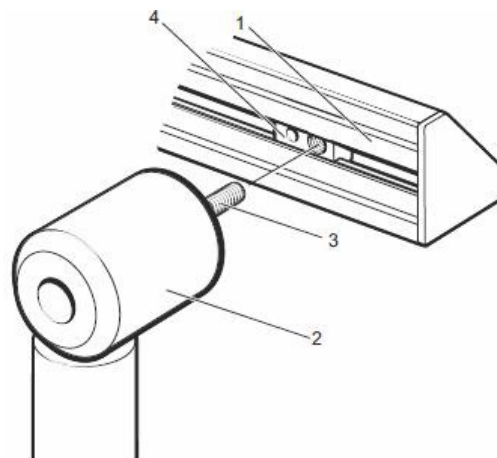

8. If the step back spacer is required, fit the step back spacer onto the step back adaptor (item 2) as shown in the image below. Position the MRS rail (item 1) to the step back spacer (item 4) and orientate the step back spacer and adaptor assembly so that the M8 screw (item 3) is properly aligned to the MRS T-nut (item 5). Screw the step back assembly to the MRS using the M8 screw (item 3)

## MRS installation and user's guide

www.renishaw.com

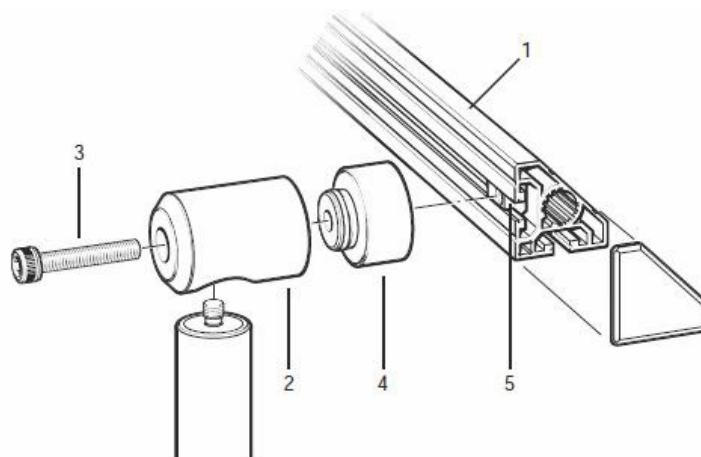

9. Repeat the relevant previous steps for the second MRS leg, hand-tightening the M8 screw on each step-back adaptor.

10. Adjust the position of the rail as required by slackening the M8 screw in the step-back adaptor and sliding the rail into position. Re-tighten the M8 screws using the hexagonal key supplied.

**i** **NOTE:** Ensure the three grub screws on each MRS foot are tightened using the hexagonal key provided.

## MRS installation and user's guide

www.renishaw.com

# Fitting heavy-duty legs to the MRS

Where an MRS installation has numerous SCP80s containing heavy stylus arrangements, or vertical stylus arrangements exceeding 190 mm, it is recommended that the optional MRS heavy duty leg kits are used to provide additional rigidity / height. These kits can be purchased separately to match the number of legs used on the MRS.

**i** **NOTE:** The MRS heavy-duty leg kit part number is A-4192-0020 and comprises 1 × heavy duty leg (Ø60 × 350 mm long, 1 × footplate and a selection of double-ended threaded studs).

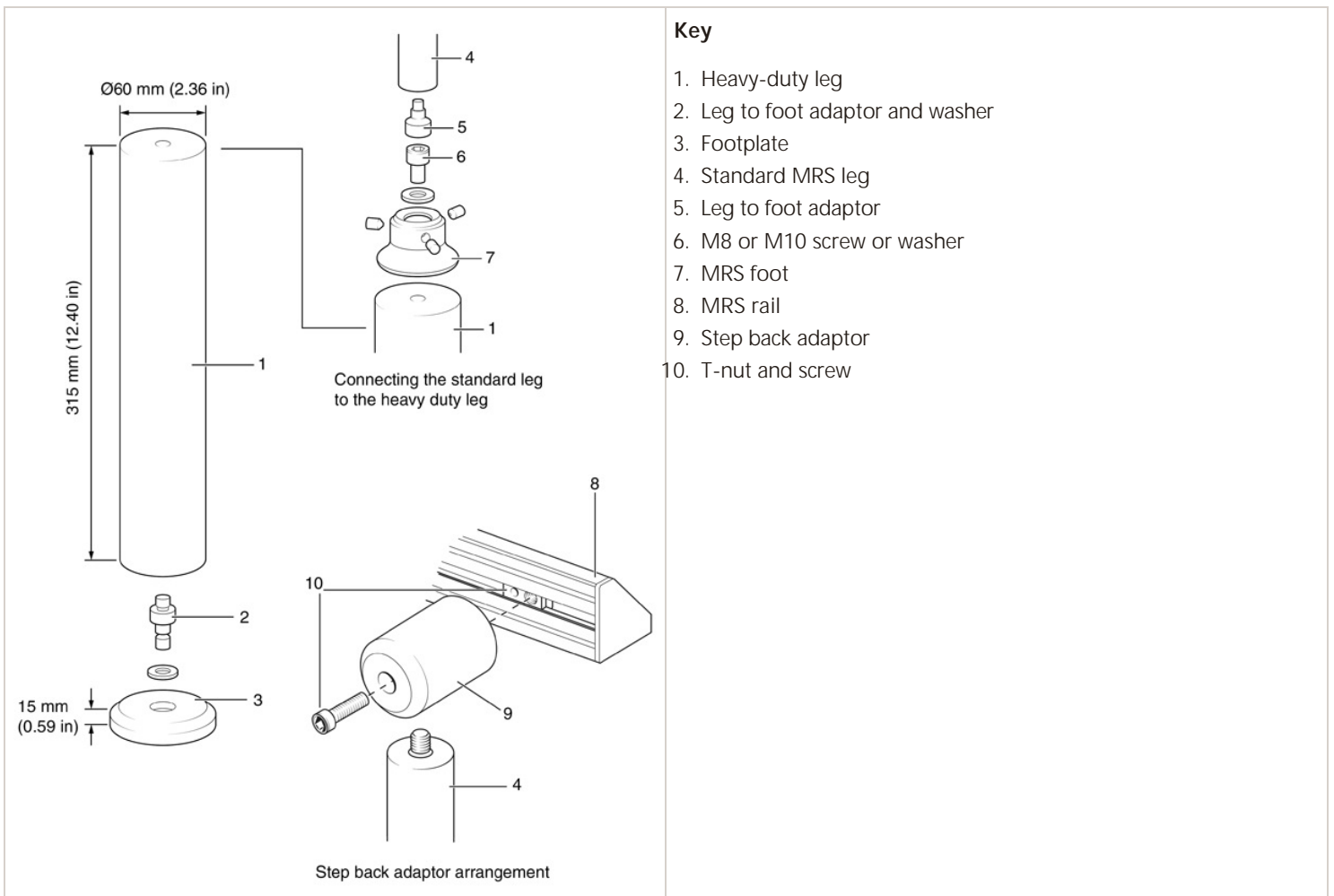



# MRS installation and user's guide

www.renishaw.com

## Installation procedure



**NOTE:** The MRS heavy-duty leg kit must be used in conjunction with the standard MRS leg assembly. The legs should be mounted using the step back adaptor method.

1. Locate the first footplate (item 3) with a suitable threaded stud on the CMM table having consideration for the required position of the MRS rail that will accommodate all loaded racks within the working volume. Fasten the footplate to the table using the double-ended threaded stud\* (item 2).
2. Locate the second footplate (item 3) at the appropriate distance along the chosen CMM axis and follow step 2 above.
3. Screw the heavy duty leg (item 1) to the top of the threaded stud (item 2) and hand-tighten. Repeat for second leg assembly.
4. Place the first MRS foot (item 7) (part of the standard MRS leg assembly) on top of the heavy duty leg (item 1) and secure using the M10 screw (item 6). Repeat for the second leg assembly.
5. Proceed with the remaining construction of the MRS system as described in the pages detailed:
  - [Aligning the MRS feet to the CMM axis.](#)
  - [Fixing the standard MRS legs to the rail using step back adaptors.](#)
  - [Fixing the standard MRS legs to the MRS foot.](#)

\* Two sets of double ended threaded studs are provided to suit different CMM table configurations. The thread sizes supplied are M10, M8 and M6. Alternatively, 3/16 " UNC and 5/16 " UNC can be obtained on request from your Renishaw supplier.

## MRS installation and user's guide

www.renishaw.com

# Fitting MRS adaptor feet

By using the optional MRS adjustable footplates shown below, the MRS rail can also be placed at different positions on the CMM's bed which ensures that a maximised working volume can be achieved. The MRS adjustable footplates can be used with the MRS standard leg and the MRS heavy duty leg arrangements.

**i** **NOTE:** The MRS adjustable footplates kit part number is A-4192-0702 and comprises two footplates.

## Fitting standard legs to the adjustable footplate

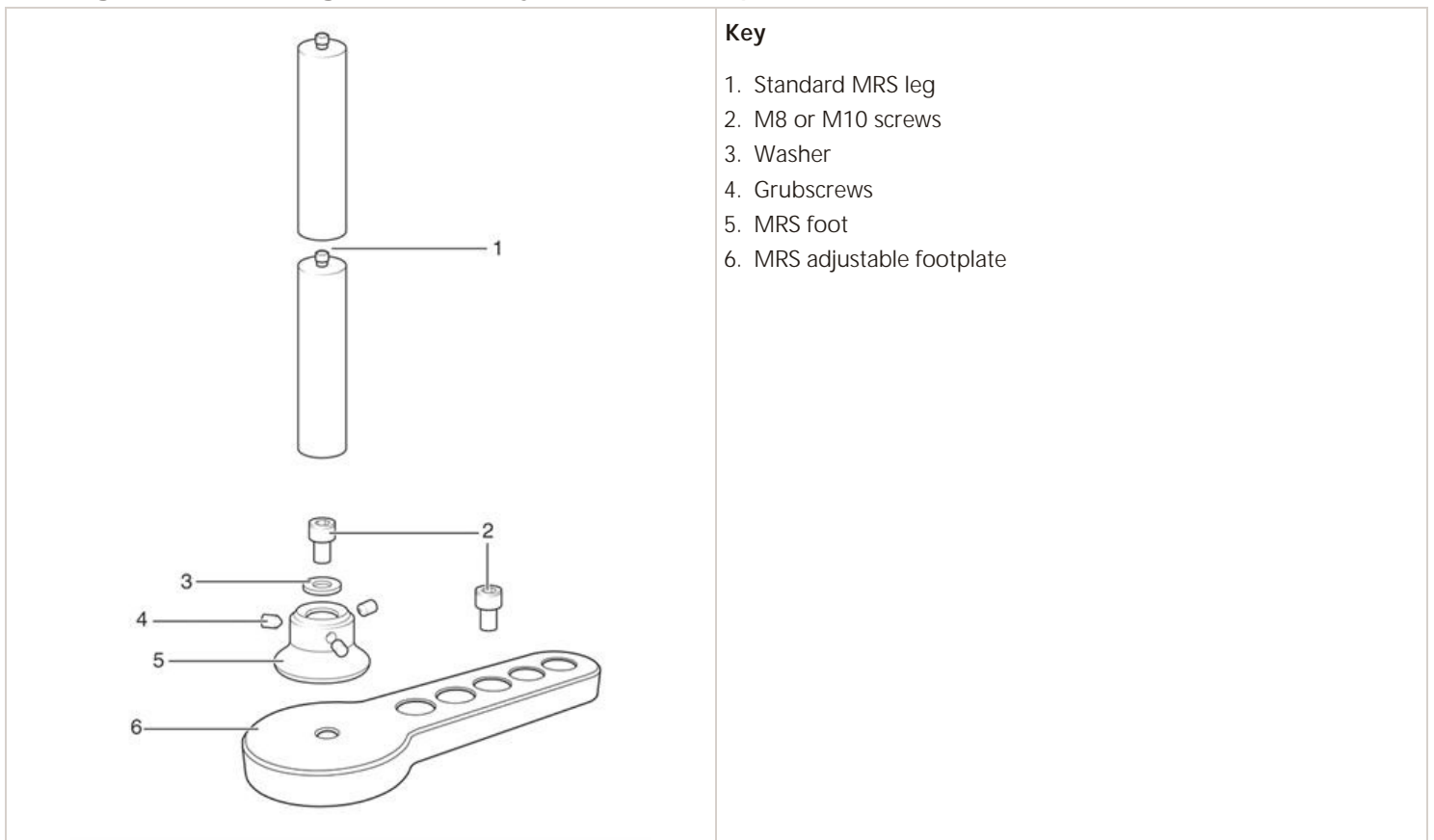

1. Fit the MRS adjustable footplate to the CMM bed.
2. Locate the first footplate with a suitable screw onto the adjustable footplate.
3. Follow steps 3 - 6 of the [installation procedure for fitting heavy duty legs](#).

## MRS installation and user's guide

www.renishaw.com

### Fitting heavy duty legs to the adjustable footplate

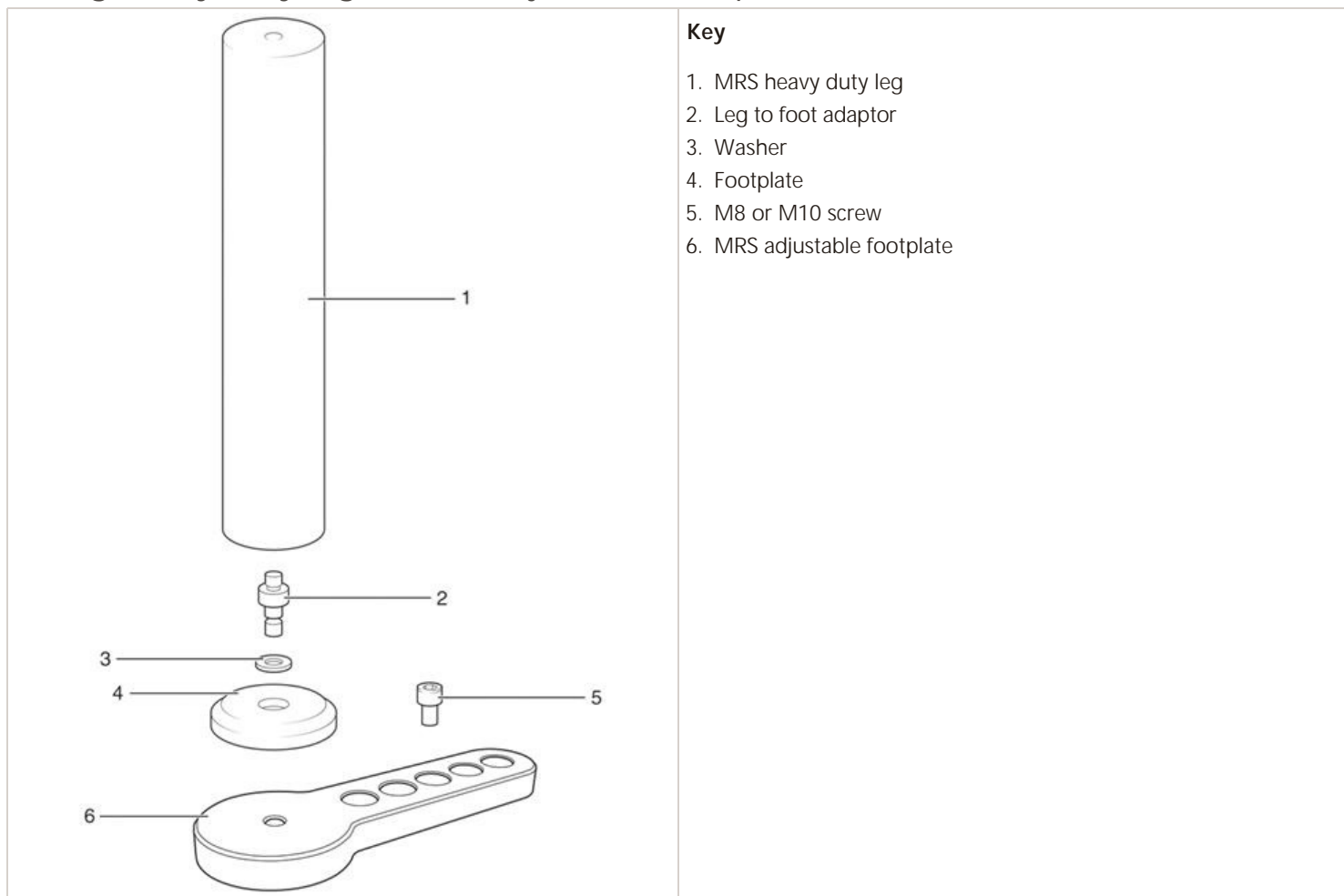

1. Fit the MRS adjustable footplate to the CMM bed.
2. Follow the steps on [fitting the MRS feet](#) and instead of fitting the feet to the CMM bed fit them to the adjustable footplate.

# MRS installation and user's guide

www.renishaw.com

## Specification summary

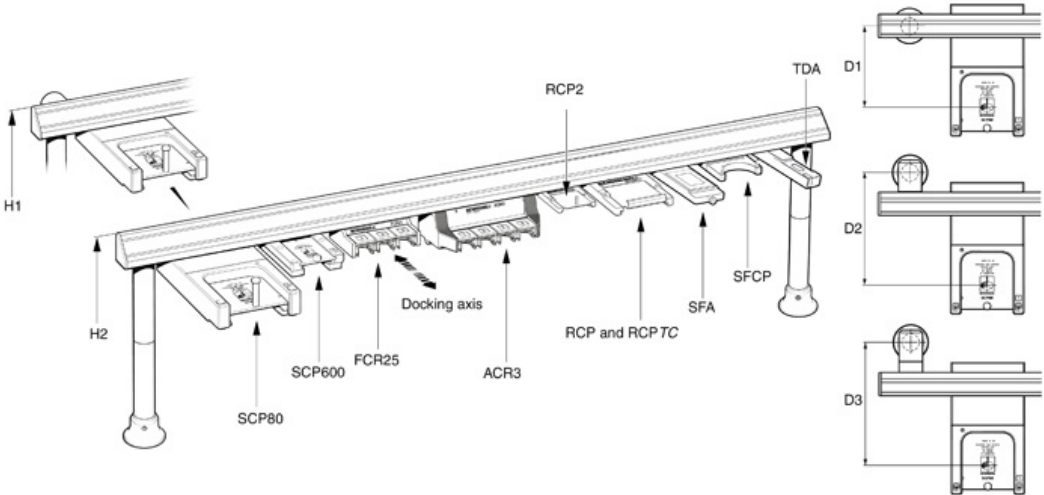

## MRS installation and user's guide

www.renishaw.com

	400 mm rail	600 mm rail	900 mm rail	1000 mm rail
<b>Rail length</b> <b>NOTE:</b> Allow additional 10 mm (0.39 in) for plastic end caps	400 mm (15.75 in)	600 mm (23.62 in)	900 mm (35.42 in)	1000 mm (39.37 in)
<b>Number of legs required</b> (recommended)	2	2‡	2‡	2‡
<b>Maximum usable rail length</b> With two legs mounted to underside of rail (as shown) With legs mounted via step back adaptor (see detail)	320 mm (12.6 in) 400 mm (15.75 in)	520 mm (20.47 in) 600 mm (23.62 in)	820 mm (32.28 in) 900 mm (35.42 in)	920 mm (36.22 in) 1000 mm (39.37 in)
<b>Height to top of rail</b> (using legs supplied with MRS kit) H1 = With two legs mounted to underside of rail (as shown) H2 = With legs mounted via step back adaptor (see detail)	325 mm (12.6 in) 317 mm (12.48 in)	325 mm (12.6 in) 317 mm (12.48 in)	325 mm (12.6 in) 317 mm (12.48 in)	325 mm (12.6 in) 317 mm (12.48 in)
<b>Height of additional single leg</b> Two versions available	62.5 mm (2.46 in) 125 mm (4.92 in)	62.5 mm (2.46 in) 125 mm (4.92 in)	62.5 mm (2.46 in) 125 mm (4.92 in)	62.5 mm (2.46 in) 125 mm (4.92 in)
<b>Height of additional heavy duty single leg</b> Ø60 mm (2.36 in)	330 mm (12.99 in)	330 mm (12.99 in)	330 mm (12.99 in)	330 mm (12.99 in)
<b>Height of additional adjustable footplate</b>	16 mm (0.63 in)	16 mm (0.63 in)	16 mm (0.63 in)	16 mm (0.63 in)

‡ Centre leg may be required in certain applications

## MRS installation and user's guide

www.renishaw.com

### Distance from port centre to leg centre (in docking axis)

	D1 Legs mounted to underside of rail (as shown)	D2 Legs mounted via step back adaptor (see detail)	D3 Legs mounted via step back adaptor and step back spacer (see detail)	Rail length required per changer unit
<b>FCR25 and FCR25 TC</b>	42.8 mm (1.69 in)	95.8 mm (3.77 in)	115.8 mm (4.56 in)	115.8 mm (4.56 in) *
<b>ACR3</b>	58.1 mm (2.29 in)	111.1 mm (4.37 in)	131.1 mm (5.16 in)	277 mm (10.91 in) **
<b>SCP600</b>	69.2 mm (2.72 in)	122.2 mm (4.81 in)	142.2 mm (5.6 in)	87 mm (3.43 in) *
<b>SCP80</b>	142.5 mm (5.61 in)	195.5 mm (7.7 in)	215.5 mm (8.48 in)	130 mm (5.12 in) *
<b>RCP2</b>	84.6 mm (3.33 in)	137.6 mm (5.42 in)	157.6 mm (6.2 in)	66 mm (2.6 in) *
<b>RCP TC-2</b>	85.6 mm (3.37 in)	138.6 mm (5.46 in)	158.6 mm (6.24 in)	94 mm (3.7 in) *
<b>TDA</b>	n/a	n/a	n/a	18 mm (0.71 in) *
<b>SFCP</b>	n/a	n/a	n/a	72 mm (2.84 in) *
<b>SFA</b>	n/a	n/a	n/a	54 mm (2.13 in) *

\* Includes 2 mm (0.08 in) extra allowance per unit

\*\* Includes 5 mm (0.2 in) extra allowance per unit

## MRS installation and user's guide

www.renishaw.com

# Accessories and spare parts

As the MRS is part of a modular system offered by Renishaw, all part numbers for the MRS system components are specified below:

Item	Quantity and description	Part number
MRS rail	1 × 400 mm long 1 × 600 mm long 1 × 900 mm long 1 × 1000 mm long	A-4192-0050 A-4192-0051 A-4192-0063 A-4192-0052
MRS leg	1 × 62.5 mm long 1 × 125 mm long	A-4192-0061 A-4192-0053
MRS heavy-duty leg	60 mm diameter × 330 mm long	A-4192-0020
MRS adjustable footplates	2 × footplates	A-4192-0702
MRS feet	1 × fixed foot	A-4192-0056
MRS step-back adaptor	1 × adaptor	A-4192-0058
MRS leg-to-foot adaptor	1 × adaptor	A-4192-0055
T-nut	1 × M8 thread nut	P-NU18-0005
MRS 4-leg kit	4 × 125 mm long	A-4192-0060
MRS 2-leg kit	2 × 125 mm long	A-4192-0059
TK63 MRS tool kit	1 × tool kit	A-4192-0070
MRS step back spacer	2 × spacers	A-4192-0014

## MRS installation and user's guide

[www.renishaw.com](http://www.renishaw.com)

# Maintenance and cleaning

The MRS has no user serviceable parts, should the unit become defective, it should be returned to the local Renishaw service centre.

Clean the MRS with a dry, lint-free cloth.



**Renishaw plc**  
New Mills, Wotton-under-Edge  
Gloucestershire, GL12 8JR  
United Kingdom

**T** +44 (0)1453 524524  
**F** +44 (0)1453 524901  
[www.renishaw.com/cmmsupport](http://www.renishaw.com/cmmsupport)



**For worldwide contact details,  
please visit our main website at  
[www.renishaw.com/contact](http://www.renishaw.com/contact)**